



HANDMADE TILE



ABOUT US

Kachic provides services to projects in different geometric shapes. The variety of hand-made tiles is 5x5, 10x10, 15x15, 20x20, 25x25 and 30x30, the most common of which is 20x20 tiles. Some geometric shapes are obtained by making cuts in the proportions of 1 to 4, 1 to 5 and 1 to 6, which produce other tiles with 5x20 and 5x30 as examples, which are called metro tiles. Among other types of tiles available in Kachic products, we can refer to hexagonal tiles, fish style tiles and tangerine tiles that are used in Moroccan spaces. If the customer needs other forms, it is possible to provide the desired dimension using waterjet.

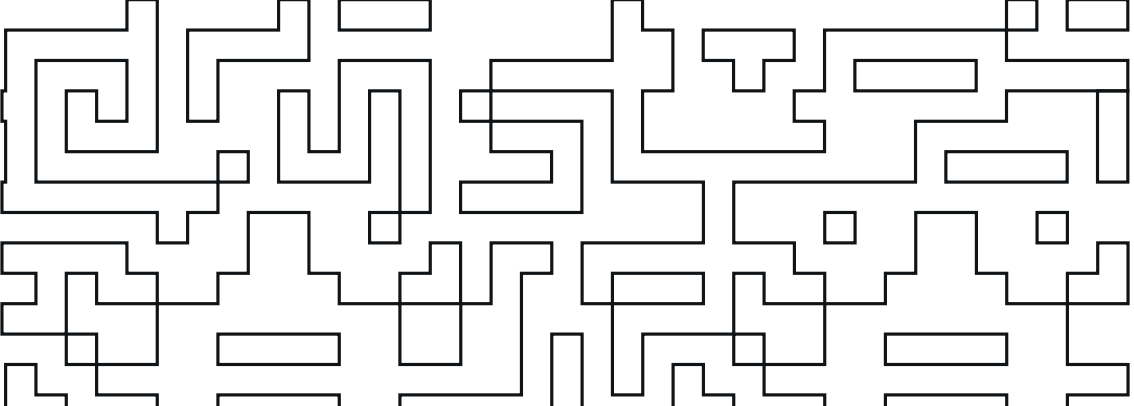

KACHIC is a group that prepares
and produces tiles traditionally.

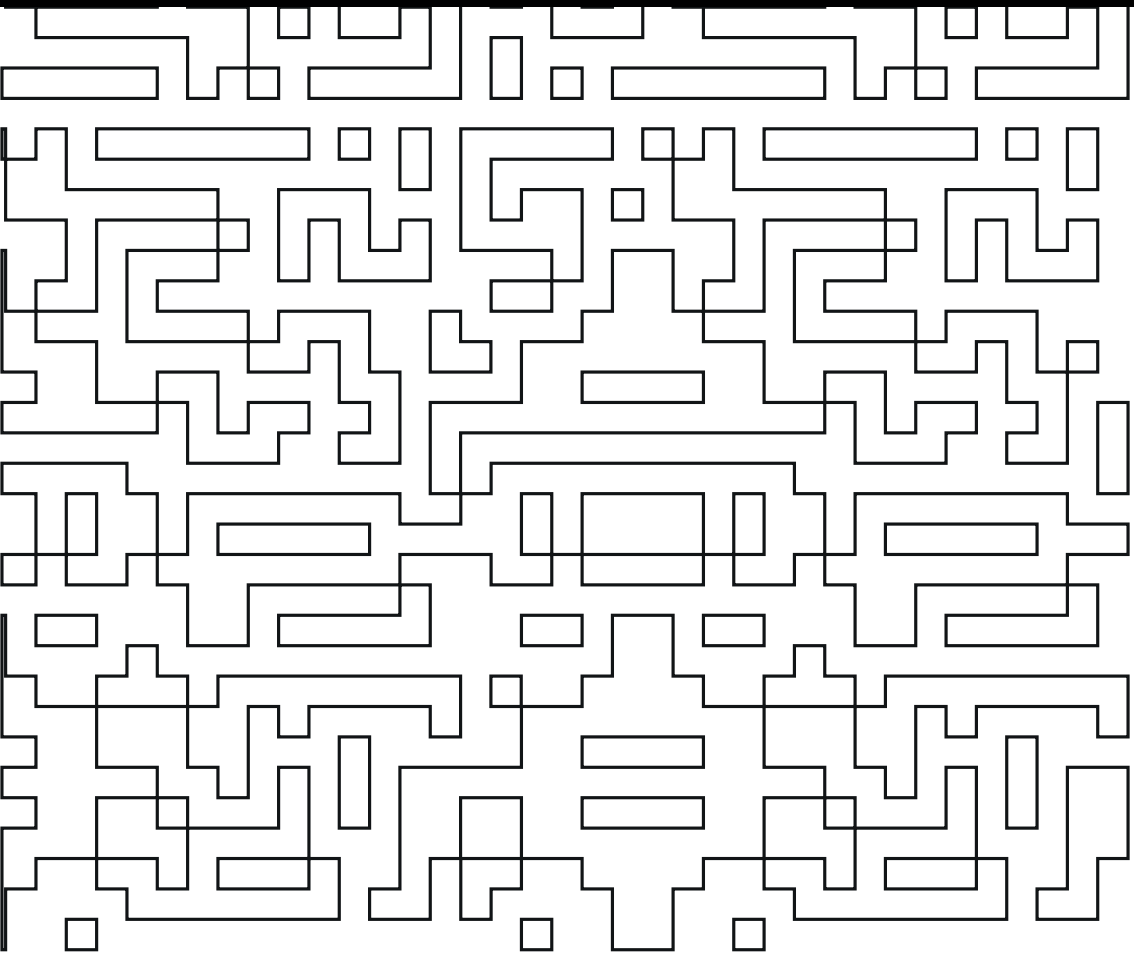

WWW.KACHIC.CO



KACHIC





The use of tile materials has been common in the world for years; It was first used in Egypt and later during the Achaemenid period. In Chaghazanbil ziggurat, for the first time in Iran, clay was baked and glazed. Therefore, with the expansion of the tile industry in Iran, obvious examples can be seen; As an example, the inscriptions of Persepolis are decorated with colored tiles. Also, the most brilliant period of using these materials in Iran dates back to the Safavid period, which is due to the impressive and soulful use of tile materials in the covering of various buildings. Therefore, it made us to use the modern technology of the world as well as the original and powerful skills of "Iranian hands" to produce Kachic and supply it to the discerning customers of the construction industry. In the past, clay was made and baked in a compact form using clay and in wooden molds; Then, by creating glaze and painting patterns and designs, they were given an appearance. Due to the weak and low adhesion of glaze and clay, the use of traditional clay in public and high-traffic spaces and outdoor spaces has been vulnerable. It is also not recommended to use these materials in spaces such as swimming pools.

KACHIC

Kachic materials are prepared from first-class ceramic 20x20 with a simple background, which is produced in a fully automatic factory with modern technology, and based on the order of the customer (builder, owner or architect), the desired design is implemented on it. Then the patterned ceramics are reheated at a temperature of 800 to 1200 degrees Celsius according to the material. In this way, re-baking is done on the tiles, which makes their glaze stronger. A clear example of these characteristics in Kachic products can be seen in the projects carried out in the flooring of high-traffic roads, inside pools and fountains.

KACHIC

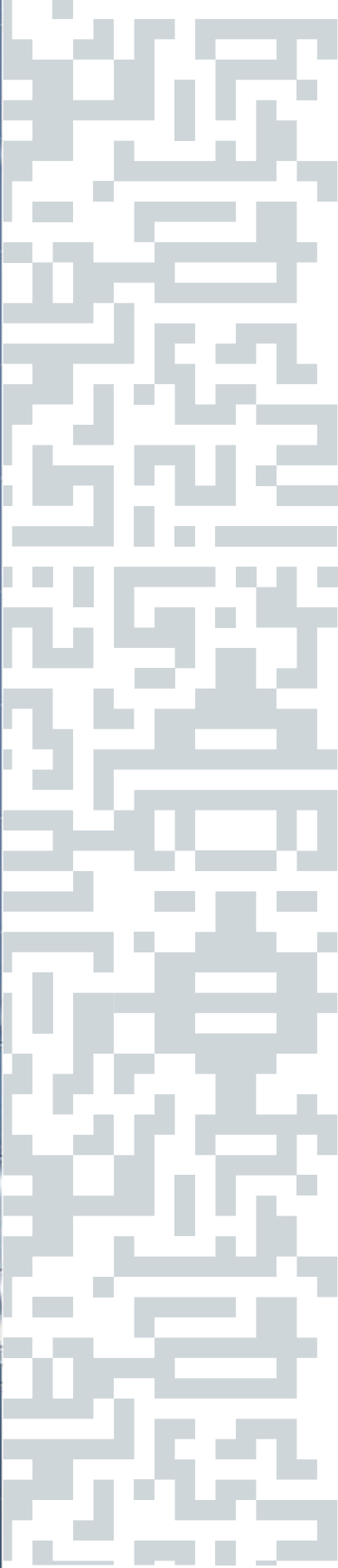
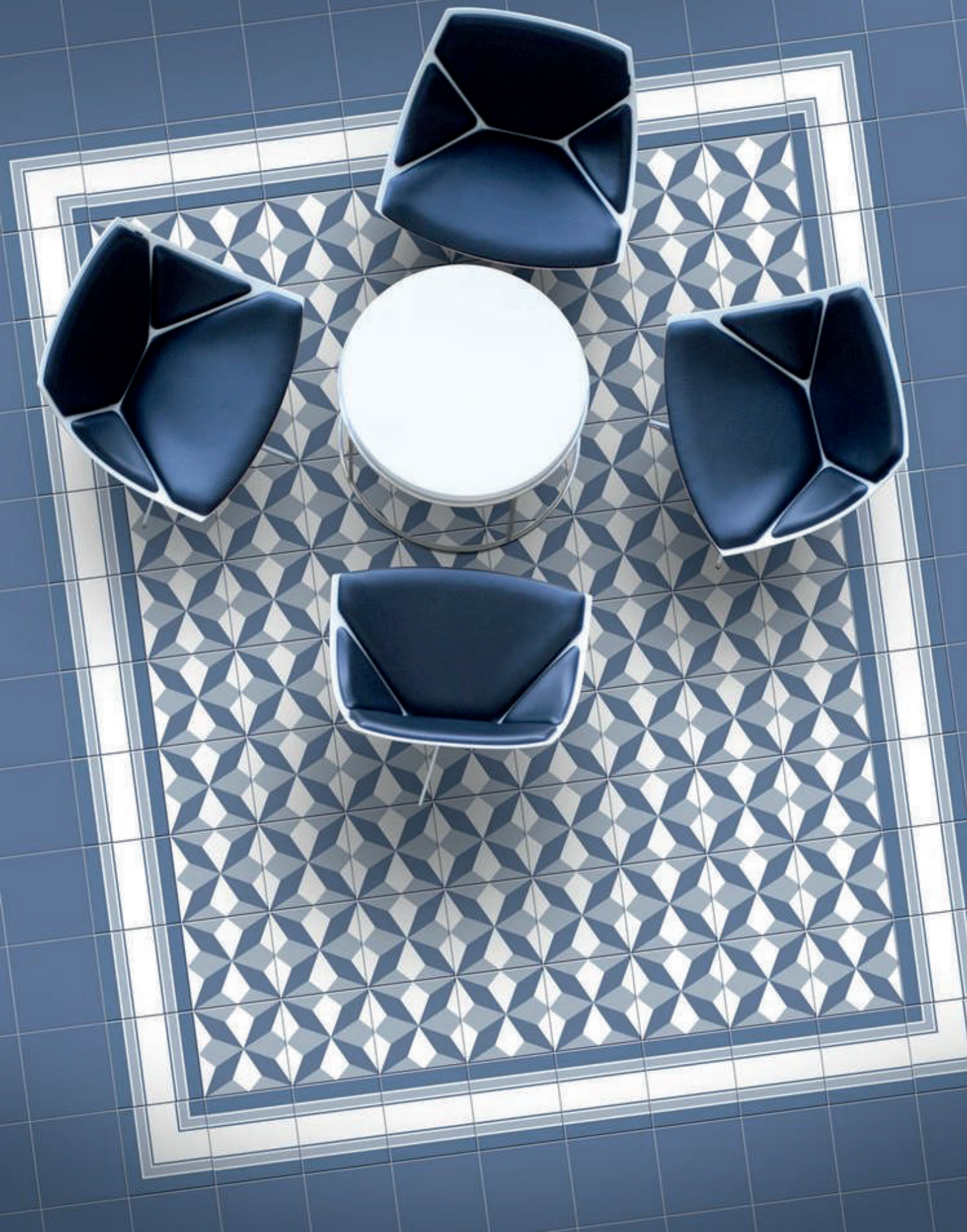

3

KACHIC MATERIALS

The clayey waffle surface is the characteristic feature of ceramics, and more silica, much less water absorption and greater thickness are characteristics of porcelain. It is recommended to use porcelain in outdoor spaces and high traffic spaces.

KACHIC





An important issue in the pricing of Kachic products is its comparability with natural stones and slab ceramics. Actually, due to the fact that tile is made by hand, its price should be much higher, but in order to develop and provide this material to the construction industry, tile is offered to the customer with minimum profit and lowest price. One of the distinctive features of Kachic is the uniqueness of its design, which is prepared and presented according to the design provided by the customer.

Therefore, tiles can be ordered in small quantities as well as very wide levels, and it is possible to procure larger quantities in the future in accordance with the previous designs, which solves the challenge of the availability of tiles with completely similar designs in the future. Among the other properties of Kachic, we can mention high durability, resistance to acid and base, resistance to scratches and impact, which can be significantly increased in case of proper foundation and no impact due to hard objects.

KACHIC



4

It is possible to create any work with Kachic.

All designs can be implemented on tiles, and if they are duplicated, they can be produced easily with the colors that the client wants. Even these designs can be in the form of a signature or a manual design. After sending and confirming the design sample, the production process begins. Kachic's versatility with any design is one of its distinctive features.

KACHIC

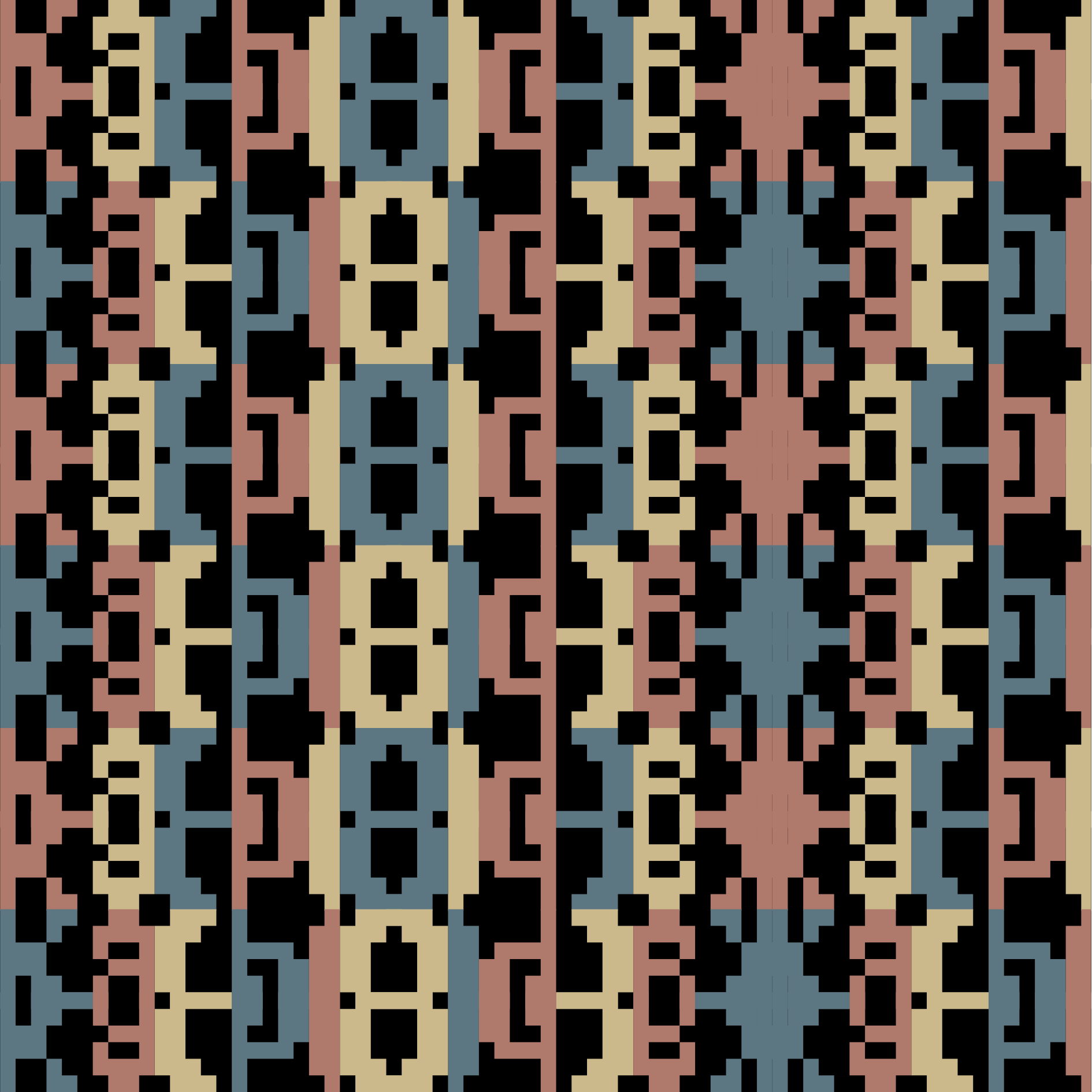



WWW.KACHIC.CO

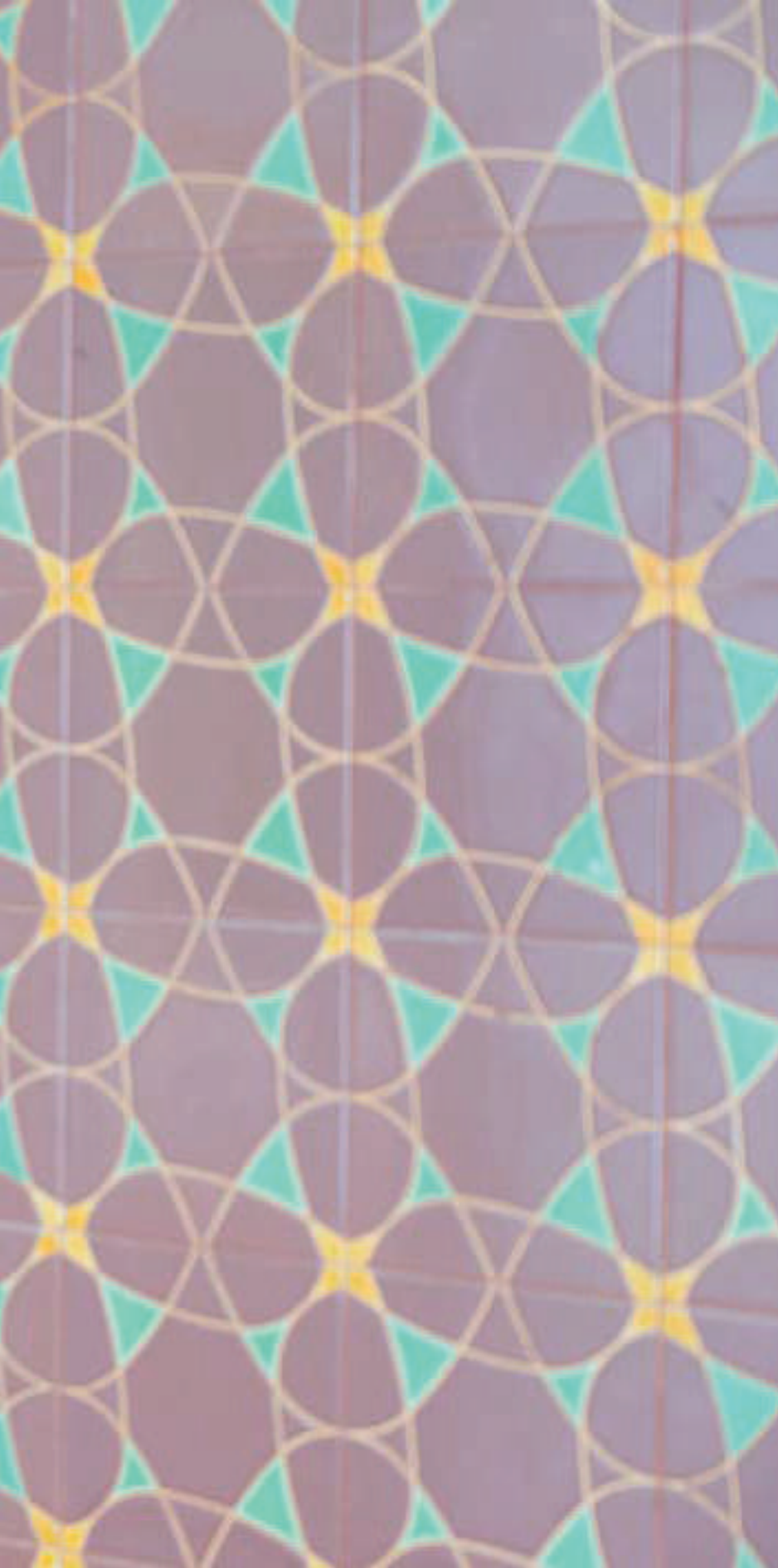

Tiles are produced in two types. Tiles with a simple single-color background, which are called single-color tiles, and tiles with different patterns and colors, which are called seven-color tiles. Also, a type of glaze is known as underglaze, which gives the tile a broken glass look under the light and gives a sense of nostalgia to the space.

To order Kachic, first, the desired design is extracted and sent to us based on the designs presented on the Kachic website or the designs desired by the client. To place an order, please call 021-28426330. After preparing samples by Kachic's team and obtaining approval from the employer, an invoice will be issued based on the total size. Then, after 25 days, the product will be delivered. Noted that the sample is provided free of charge.

Fifty percent of the invoice amount is paid by the customer after the sample is presented and at the stage of issuing the invoice, and the remaining fifty percent is settled after the shipment is ready and before shipping.

KACHIC

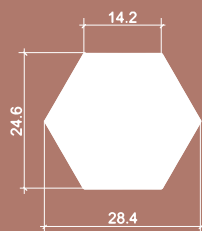

Patterned hexagon
20 cm
Monochrome hexagon
20 cm

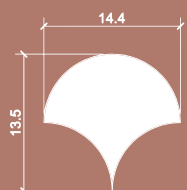

Code 1 fish style

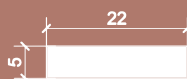

22*5 Brick plate



7* 31 Brick plate

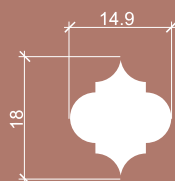

Code 3 special color bergamot

KACHIC

22*5 Brick plate

7* 31 Brick plate

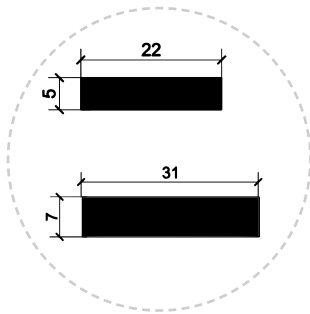

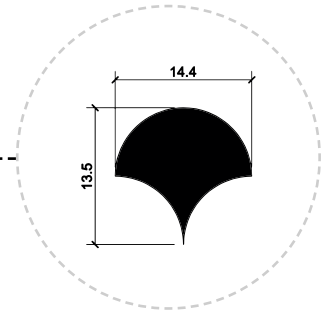

Code 1 fish style



KACHIC

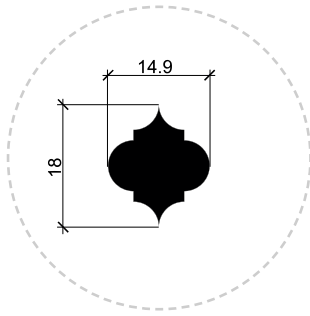

Code 3 special color bergamot

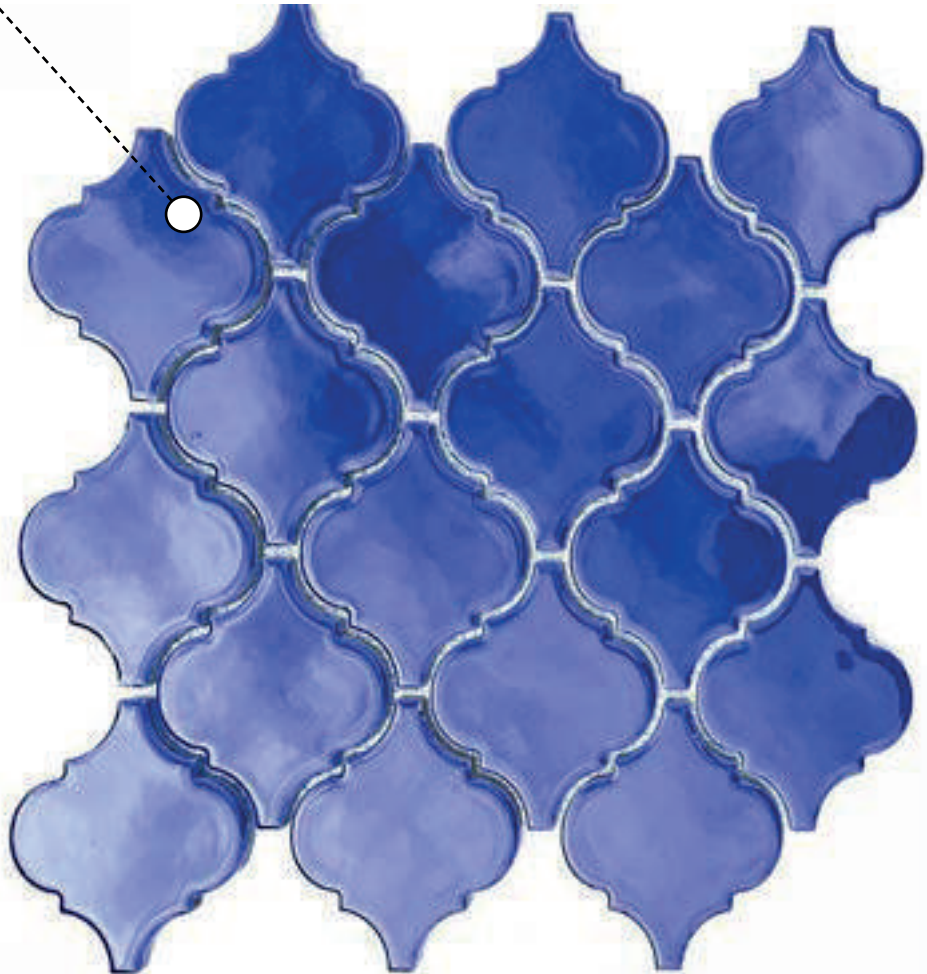

WWW.KACHIC.CO

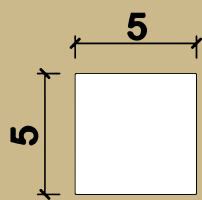
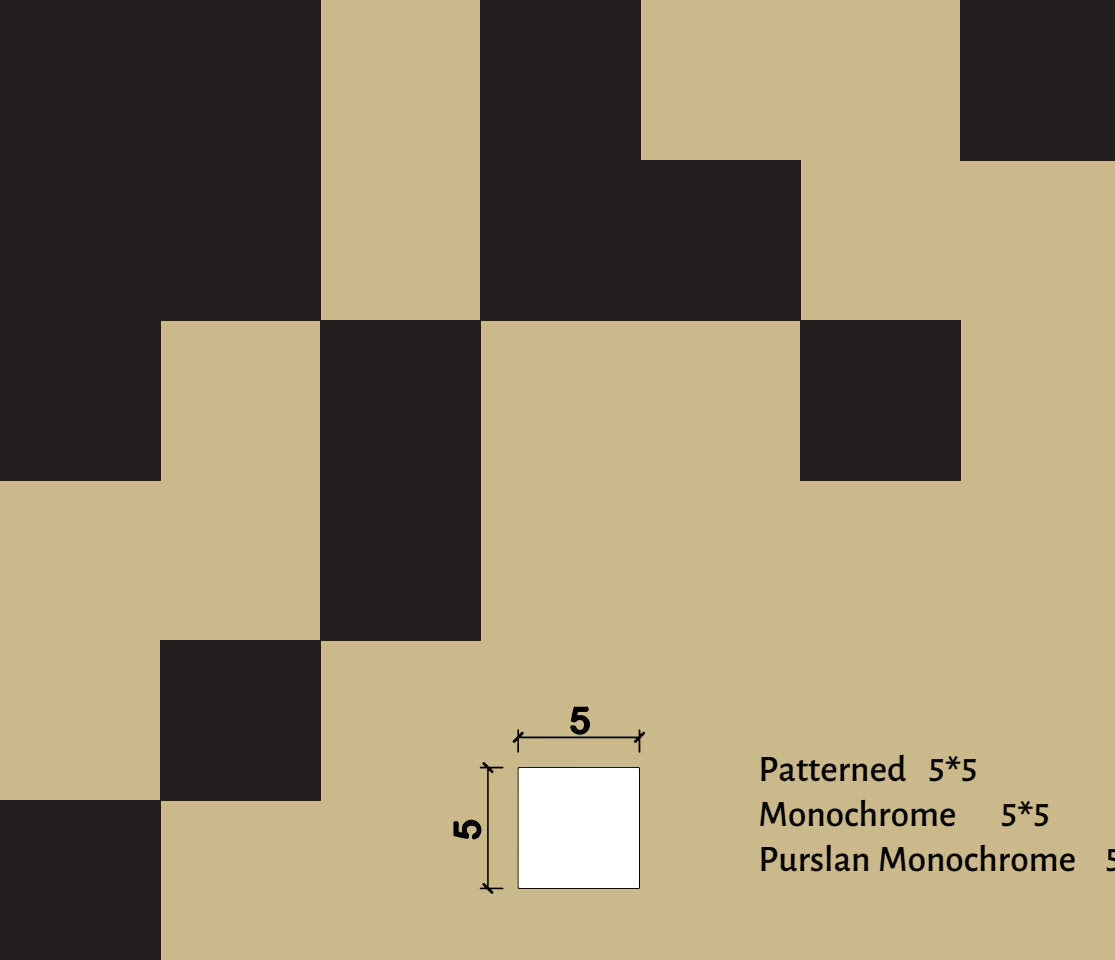

Patterned 5*5
Monochrome 5*5
Purslan Monochrome 5*5

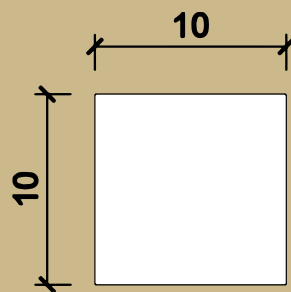

Patterned 10*10
Purslan Patterned 10*10
Monochrome 10*10
Monochrome Under Glaze 10*10
Purslan Monochrome 10*10
Purslan Monochrome Under Glaze 10*10



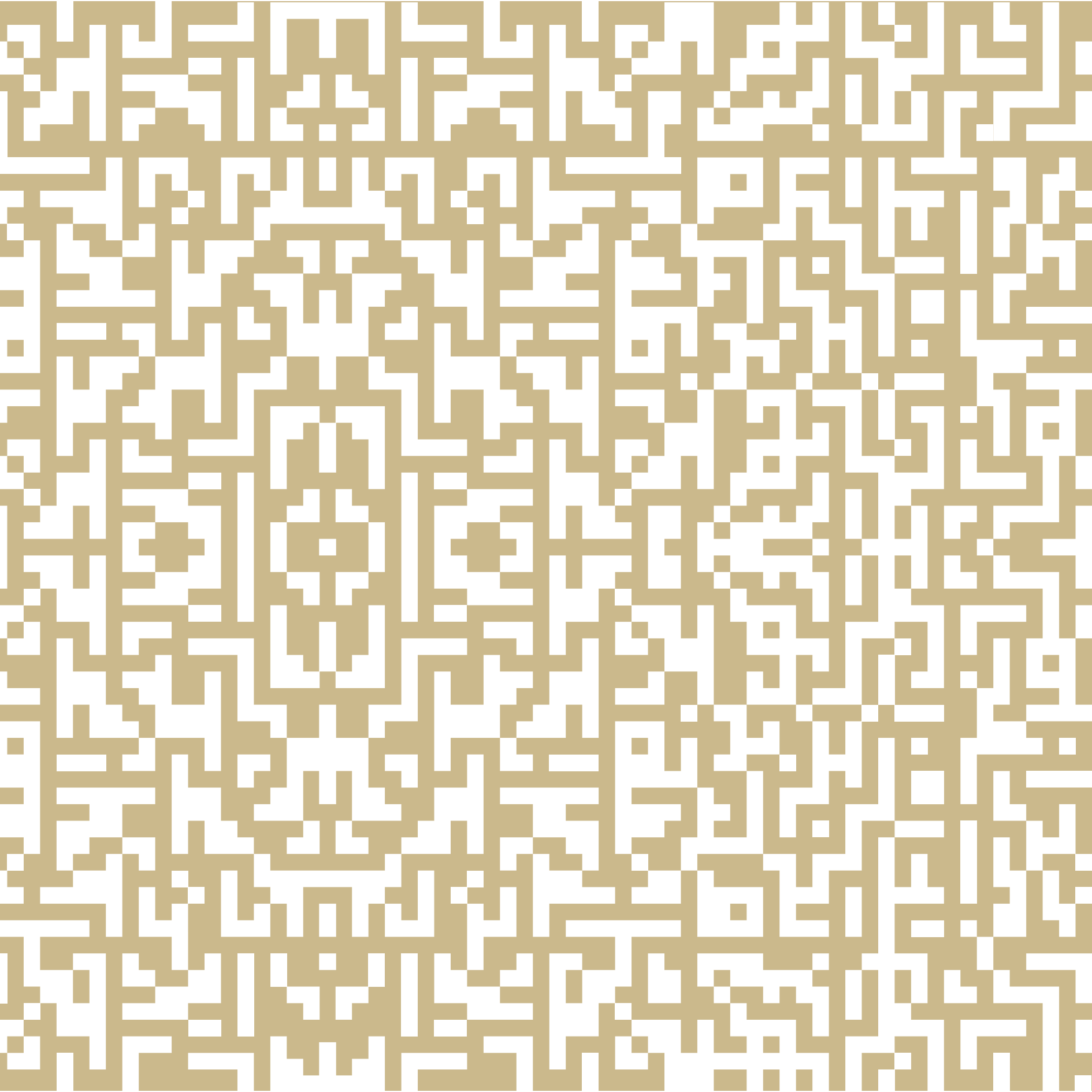

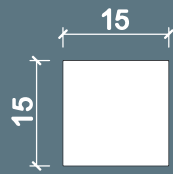
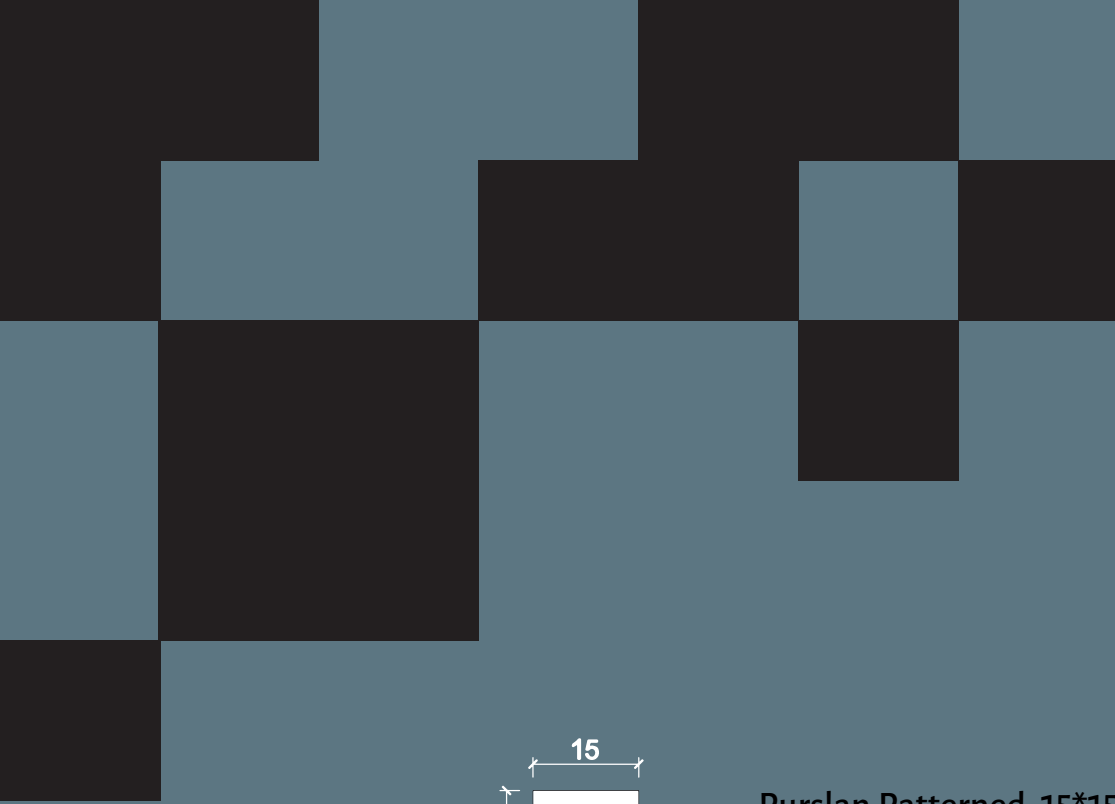

Purslan Patterned 15*15
Purslan Monochrome 15*15

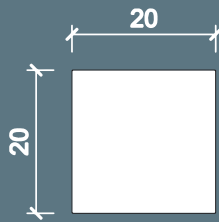

Patterned 20*20
Purslan Patterned 20*20
Monochrome 20*20

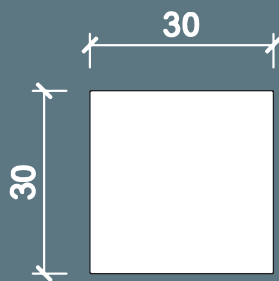

Patterned 30*30
Purslan Patterned 30*30

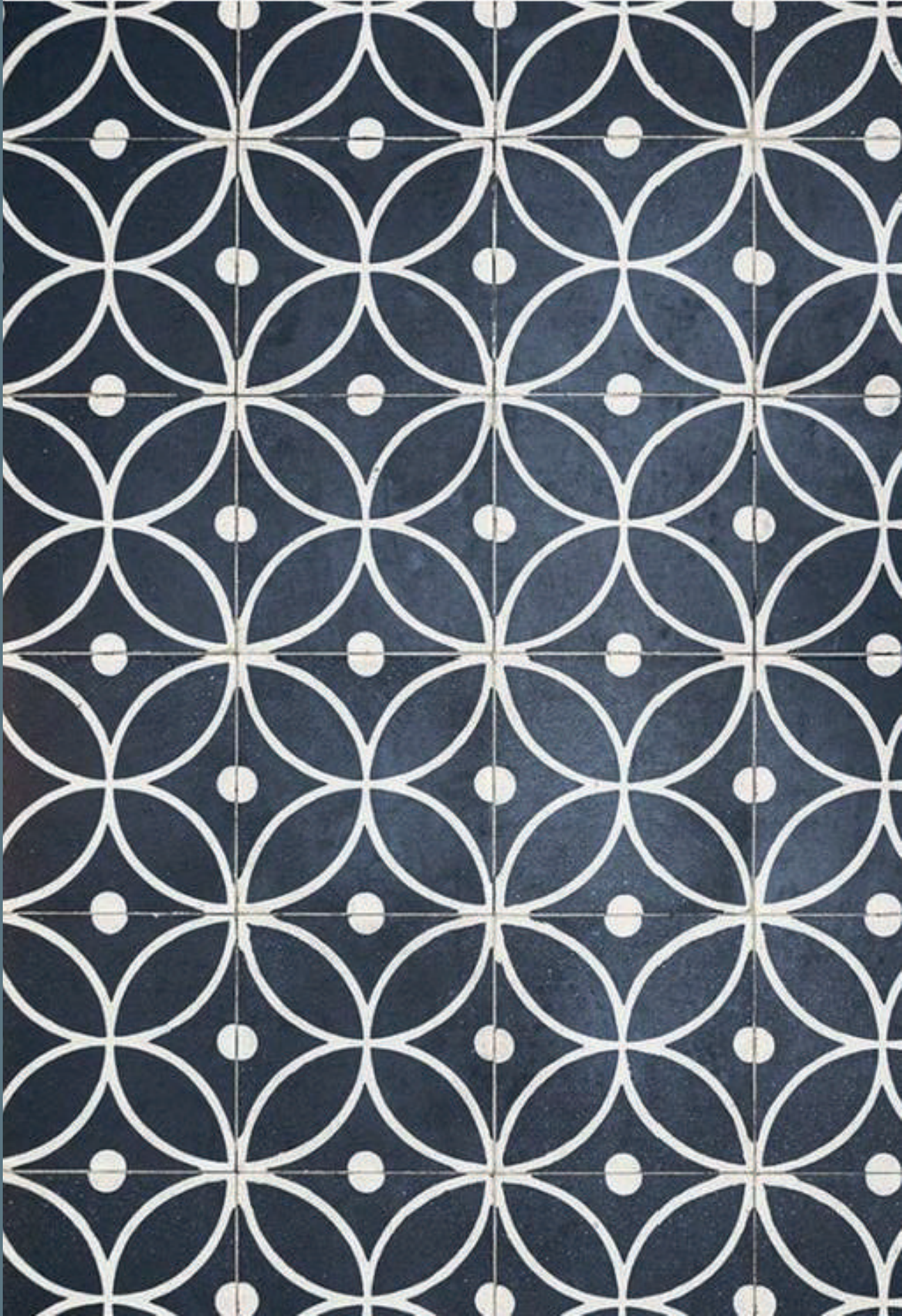



KACHIC

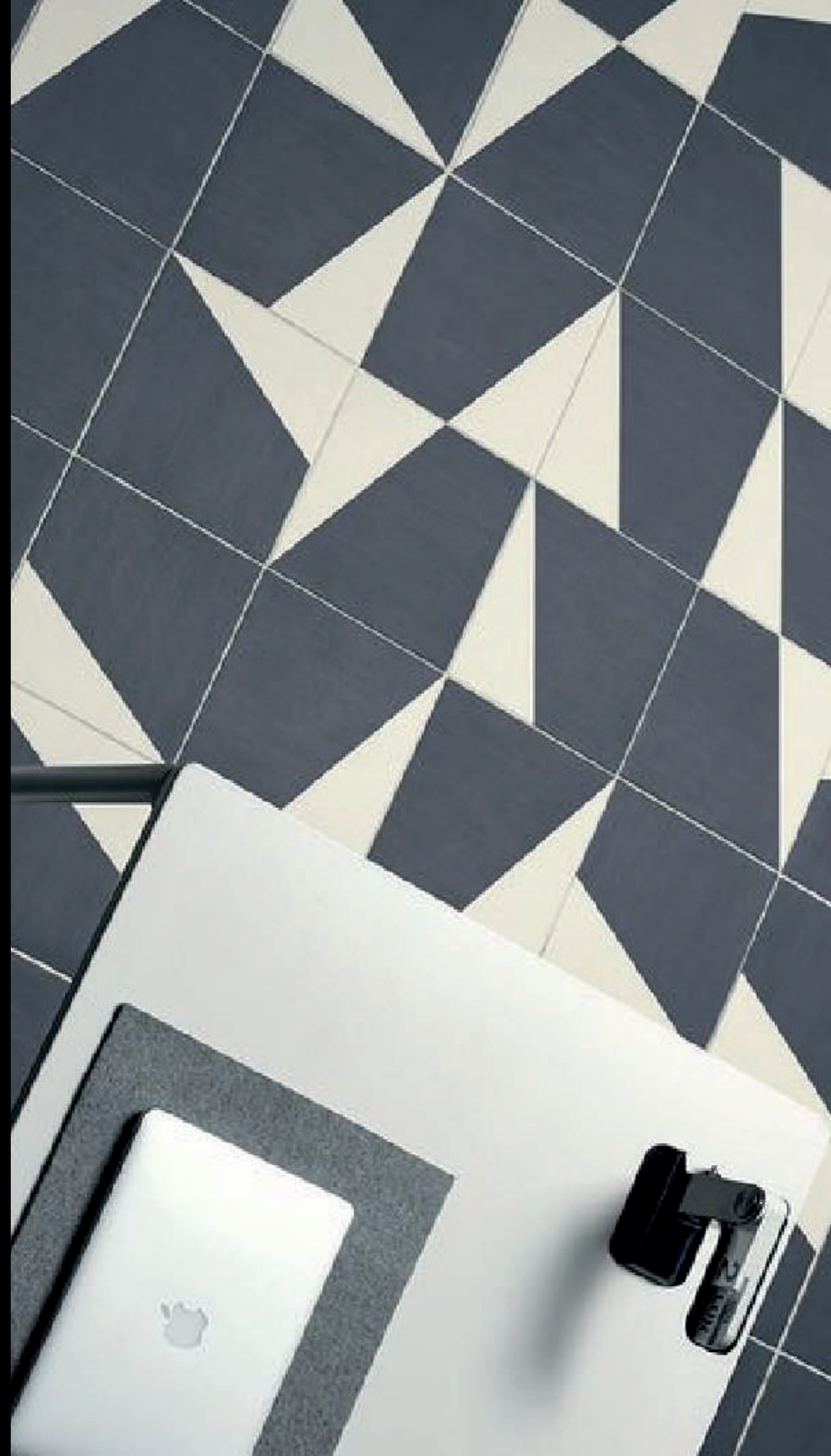



KACHIC





HE



KACHEL

ALL SUGGESTION

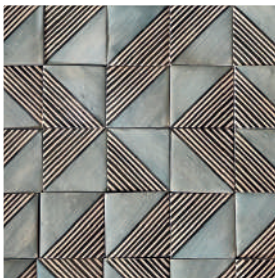
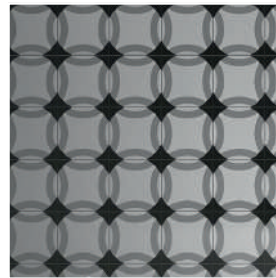
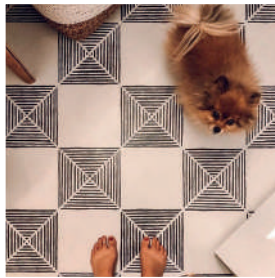
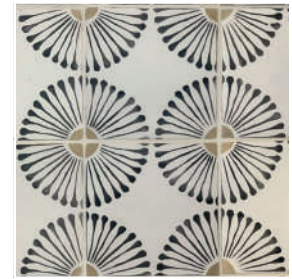
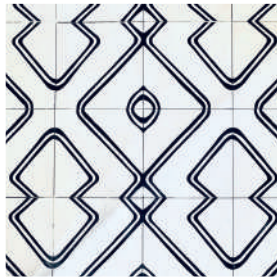
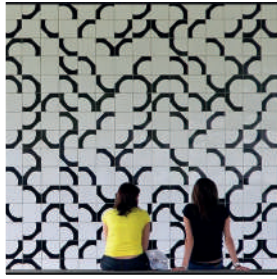
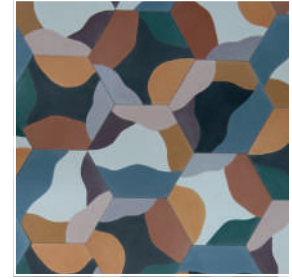
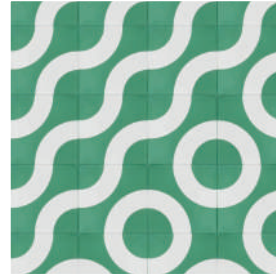
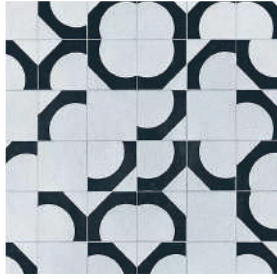
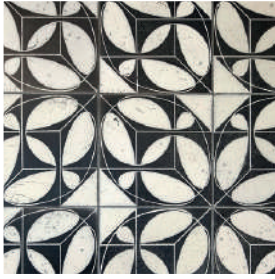

ALL SUGGESTION

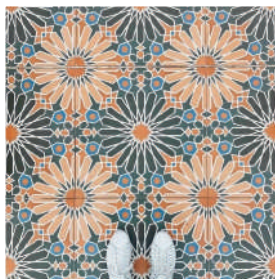
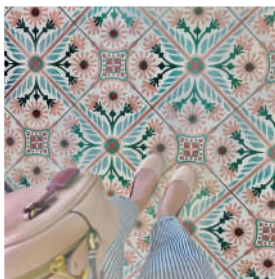
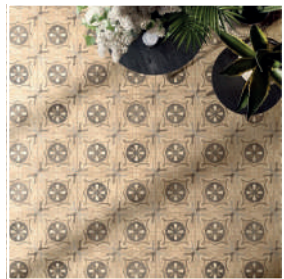
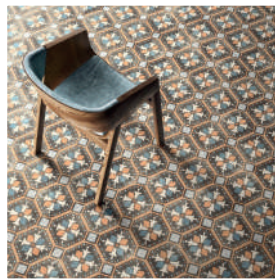
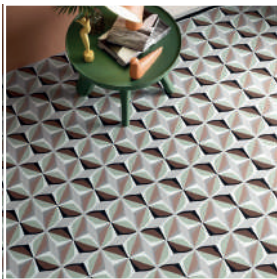
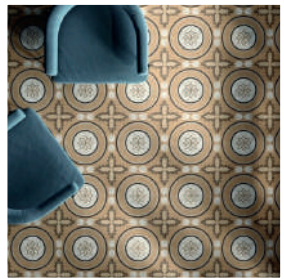
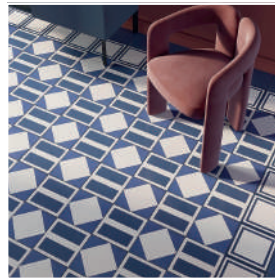
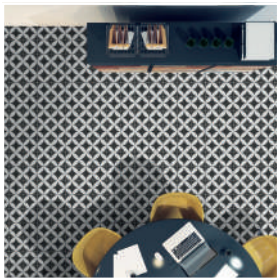
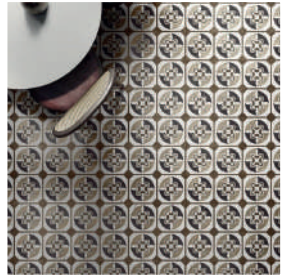
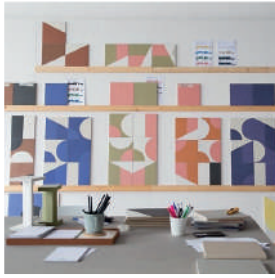

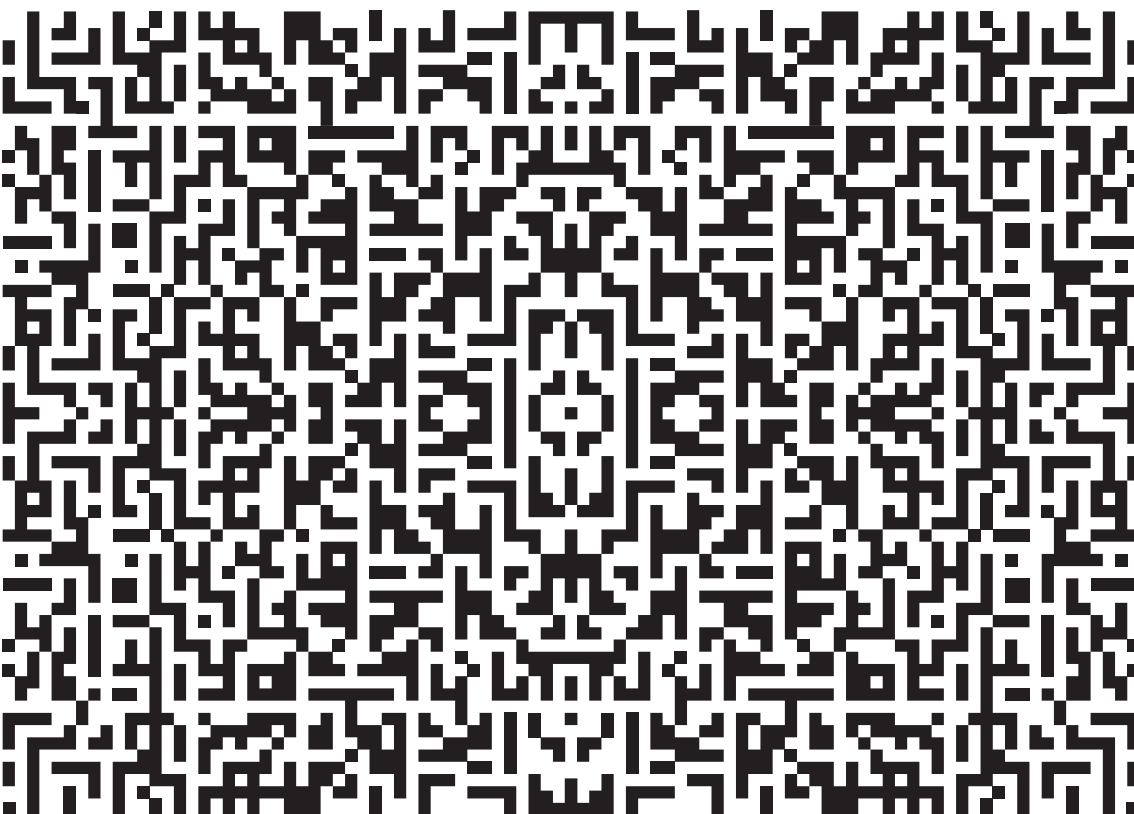

KACHIC



WWW.KACHIC.CO



[INSTAGRAM.COM/KACHIC.CO](https://www.instagram.com/KACHIC.CO)



[+982128426330](https://wa.me/982128426330)